Laplace Transforms, Part 3:

Basic Parallel Circuit Analysis

Course No: E04-046

Credit: 4 PDH

Tom Bertenshaw, Ed.D., P.E.



Continuing Education and Development, Inc.
22 Stonewall Court
Woodcliff Lake, NJ 07677

P: (877) 322-5800
info@cedengineering.com

Laplace Transforms in Design and Analysis of Circuits©

Part 3 - Basic Parallel Circuit Analysis

Simple Two Loop

In Part 2, Laplace techniques were used to solve for the output in simple series reactive circuits. This module will examine the techniques used in approaching the solution to two and three loop parallel circuits with reactive components. Parallel circuits that contain a number of loops beyond three will not be exemplified, as any number of loops can be reduced to two or three by the use of Thevenin's or Norton's theorem, or by merely extending the procedures developed here.

Consider the following two loop system:

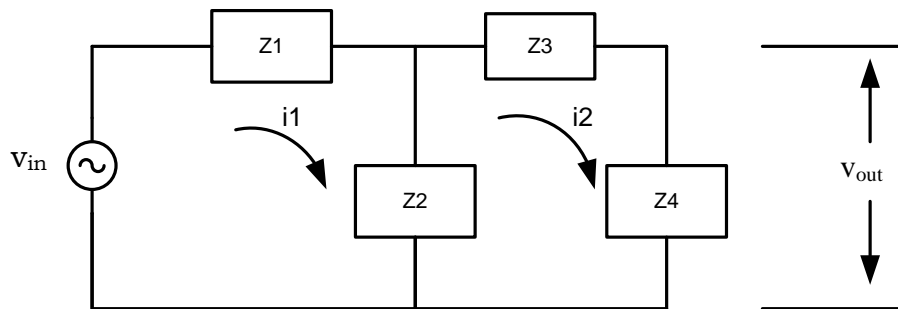

Writing the circuit equation for each loop; reveals that there are two equations in two unknowns (i_1 & i_2) that characterize the circuit.

$$v_{in} = (z_1 + z_2)i_1 - z_2i_2$$
$$0 = -z_2i_1 + (z_2 + z_3 + z_4)i_2$$

There are several techniques available for solving systems of linear equations that have the same number of equations as unknowns, and of those, we will use Cramer's Rule for now (If you want a quick refresher on the use of Cramer's Rule for solving systems of linear equations, see Appendix A). Suppose we have the following values for z_1 through z_4

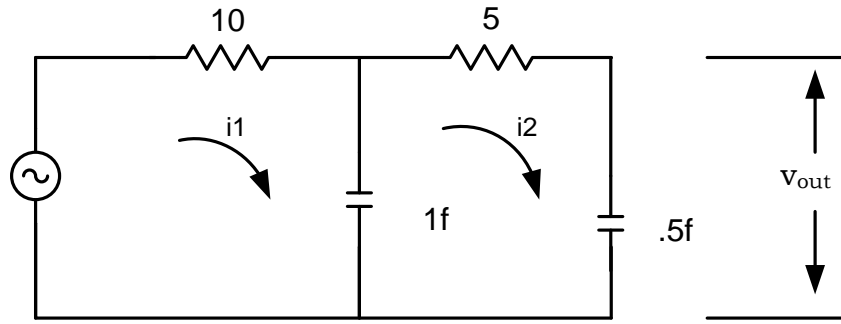

Writing the equations for the two loops;

$$v_{in} = 10i_1 + \int (i_1 - i_2) dt$$

$$0 = -\int i_1 dt + 5i_2 + 3\int i_2 dt$$

Question? How was the factor $3\int i_2 dt$ developed?

Since the defining equation for capacitor behavior is $i_c = C \frac{dv_c}{dt}$, it follows that

$$v_c = \frac{1}{C} \int i_c dt.$$

We can probably reduce the labor (and anguish) if the above two circuit equations are converted to their Laplace transforms. Looking at the transformed circuit;

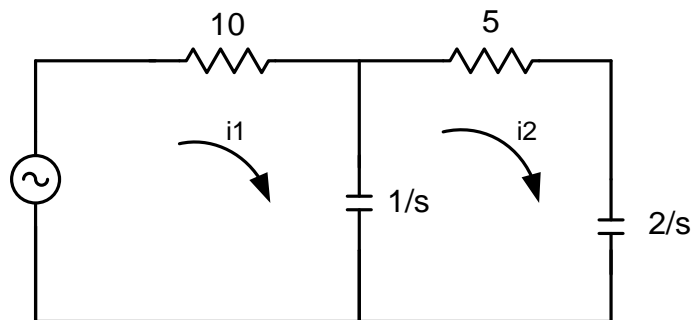

the circuit equations are re-written as;

$$v_{in}(s) = \left(10 + \frac{1}{s}\right) i_1(s) - \frac{1}{s} i_2(s)$$

$$0 = -\frac{1}{s} i_1(s) + \left(5 + \frac{3}{s}\right) i_2(s)$$

Re-writing these equations as matrices;

$$\begin{bmatrix} \left(10 + \frac{1}{s}\right) & -\frac{1}{s} \\ -\frac{1}{s} & \left(5 + \frac{3}{s}\right) \end{bmatrix} \begin{bmatrix} i_1(s) \\ i_2(s) \end{bmatrix} = \begin{bmatrix} v_{in}(s) \\ 0 \end{bmatrix}$$

First, find the determinant.

$$Det. = \left(10 + \frac{1}{s}\right)\left(5 + \frac{3}{s}\right) - \frac{1}{s^2} = \frac{50s^2 + 35s + 2}{s^2} = \frac{50(s^2 + .7s + .04)}{s^2}$$

The task is find v_{out} as a function of the driver, and recognizing that

$$v_{out}(s) = i_2(s)\left(\frac{2}{s}\right).$$

First we'll find the impulse response to gain an idea of the form of the transient response of the circuit. Because $i_2(s)$ is the only current involved in finding $v_{out}(s)$ we need not solve for $i_1(s)$, except to satisfy curiosity. Solving for $i_2(s)$;

$$\frac{\begin{bmatrix} \left(10 + \frac{1}{s}\right) & 1 \\ -\frac{1}{s} & 0 \end{bmatrix}}{Det.} = \frac{s}{50(s^2 + .7s + .04)} = \dot{i}_2(s)$$

and the output voltage response to the current impulse is

$$v_{out}(s) = \left(\frac{s}{50(s^2 + .7s + .04)}\right)\left(\frac{2}{s}\right) = .07\left(\frac{1}{s + .637} - \frac{1}{s + .063}\right)$$

in turn then

$$v_{out}(t) = .07(e^{-.063t} - e^{-.637t}) \quad \leftarrow \text{Eq. 1}$$

Indicating that the transient response, for all practical purposes, is \approx zero at $t \approx 67$ seconds (the output is less than 1mV - recall that in previous modules, e^{-6} was defined to be about zero).

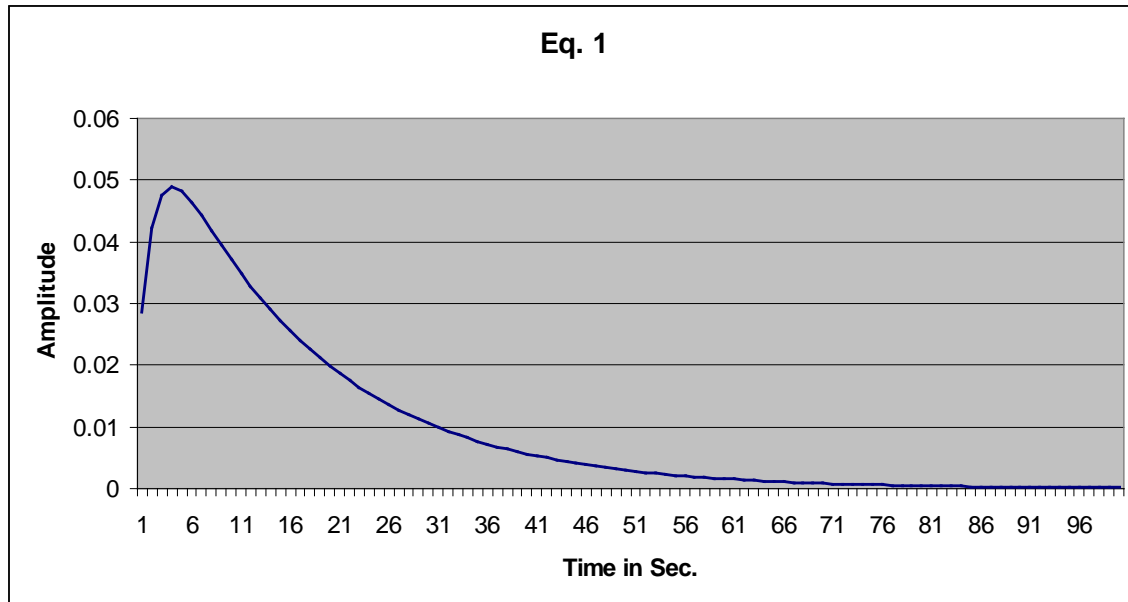

Suppose that a driver of $\sin(.1t)$ is applied as $v_{in}(t)$. Often parameters are chosen, in this case the frequency, to exaggerate some aspect of the response for illustration purposes.

Then $i_2(s)$ equals

$$\frac{\begin{bmatrix} \left(10 + \frac{1}{s}\right) & \frac{.1}{s^2 + .1^2} \\ -\frac{1}{s} & 0 \end{bmatrix}}{Det.} = \frac{\left(\frac{1}{s}\right)\left(\frac{.1}{s^2 + .01}\right)s^2}{50(s^2 + .7s + .04)} = \frac{.02s}{(s^2 + .7s + .04)(s^2 + .1^2)}$$

Since $v_{out}(s) = i_2(s)\left(\frac{2}{s}\right)$, then

$$v_{out}(s) = \frac{.04}{(s^2 + .7s + .04)(s^2 + .01)} \approx \frac{5}{s + .063} - \frac{.17}{s + .637} - \frac{.17(.01)}{s^2 + .1^2} + \frac{4.83s}{s^2 + .1^2}$$

(if you need a refresher on Partial Fraction Expansion, particularly with respect to finding factors on complex denominators, refer to Laplace Transforms in Design and Analysis of Circuits© Part 2), and finally:

$$v_{out}(t) = 5e^{-.063t} - .17e^{-.637t} + .5 \cos(.1t) - .17 \sin(.1t) \quad \leftarrow \text{Eq. 2}$$

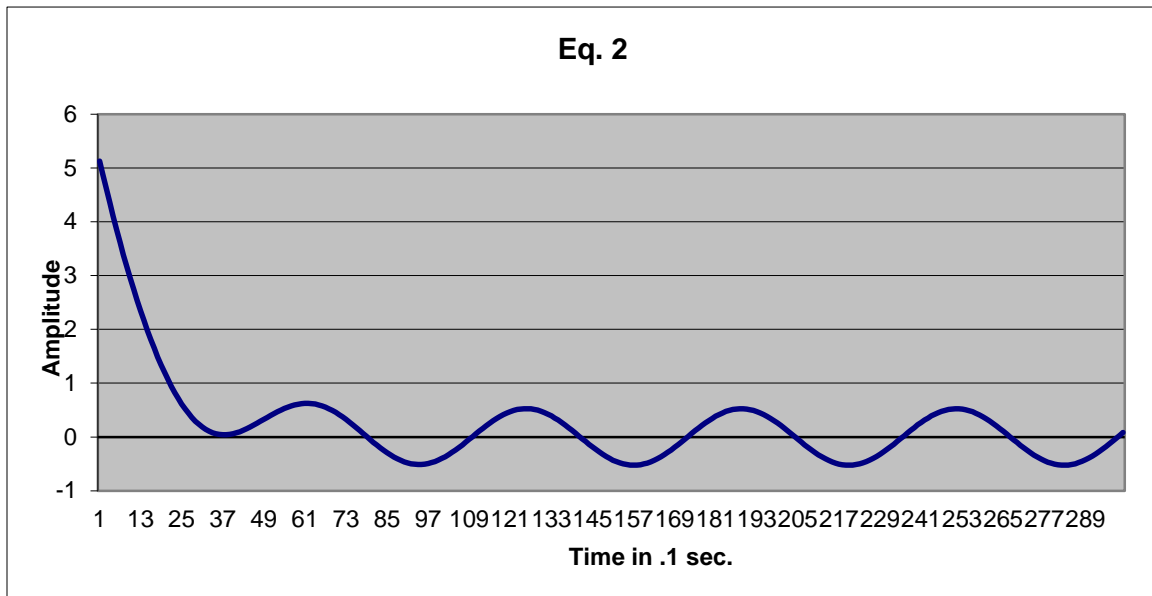

Again, please note that the output contains two distinct components: the transient response and the steady state response. The transient response is the time limited contribution of the impulse response (amplitude modified by the nature of the driver). The steady state response has the characteristics of the driver and continues until the drive is removed. All responses will contain these two components.

The RLC

Another, and very significant, circuit is the analog of the series RLC network; as expected it is a parallel RLC network; often known as a "parallel tank" circuit. Its properties are such that it presents a very high impedance at the resonant frequency rendering the circuit very useful in filtering and frequency determination applications. Like other classic circuits this one can also be implemented using active components. However it is an understanding of the response that is sought at this time and not the techniques involved in mimicking reactive components with active components. Those design techniques will be developed in subsequent modules within this series.

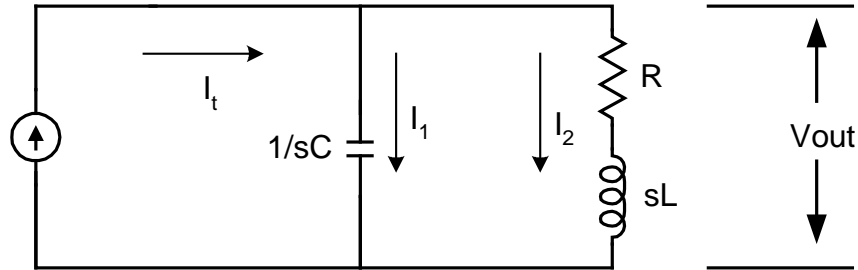

$$i_t = i_1 + i_2$$

R is the combined DC resistance of the inductor and any circuit resistance/resistors. By inspection,

$$i_1 = sCV_c$$

$$i_2 = \frac{V_{out}}{sL + R}$$

Since $V_c = V_{out}$, and $i_t = i_1 + i_2$ we can take advantage of that and write the circuit equation as

$$i_t = \left(sC + \frac{1}{sL + R} \right) V_{out}$$

or

$$\frac{V_{out}}{i_t} = \frac{sL + R}{s^2 LC + sCR + 1} = \frac{sL + R}{LC \left(s^2 + \frac{R}{L}s + \frac{1}{LC} \right)}$$

Suppose the following circuit exists, and that we wish to know its impulse response. (See Appendix C for a simple but relatively effective current driver)

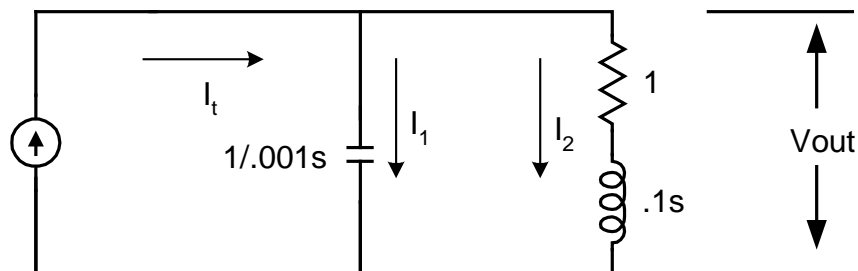

Assume $i_t(t) = \delta(t)$. Putting some flesh to the transfer function

$$v_{out}(s) = \frac{10000(.1s + 1)}{s^2 + 10s + 10000} = \frac{1000(s + 5 + 5)}{(s + 5)^2 + 99.87^2} = \frac{1000(s + 5)}{(s + 5)^2 + 99.87^2} + \frac{(99.87)(50.07)}{(s + 5)^2 + 99.87^2}$$

$$v_{out}(t) = 1000e^{-5t} \cos(99.87t) + 50.07e^{-5t} \sin(99.87t) \approx 1001e^{-5t} \sin(99.87t + 87^\circ) \leftarrow \text{Eq 3}$$

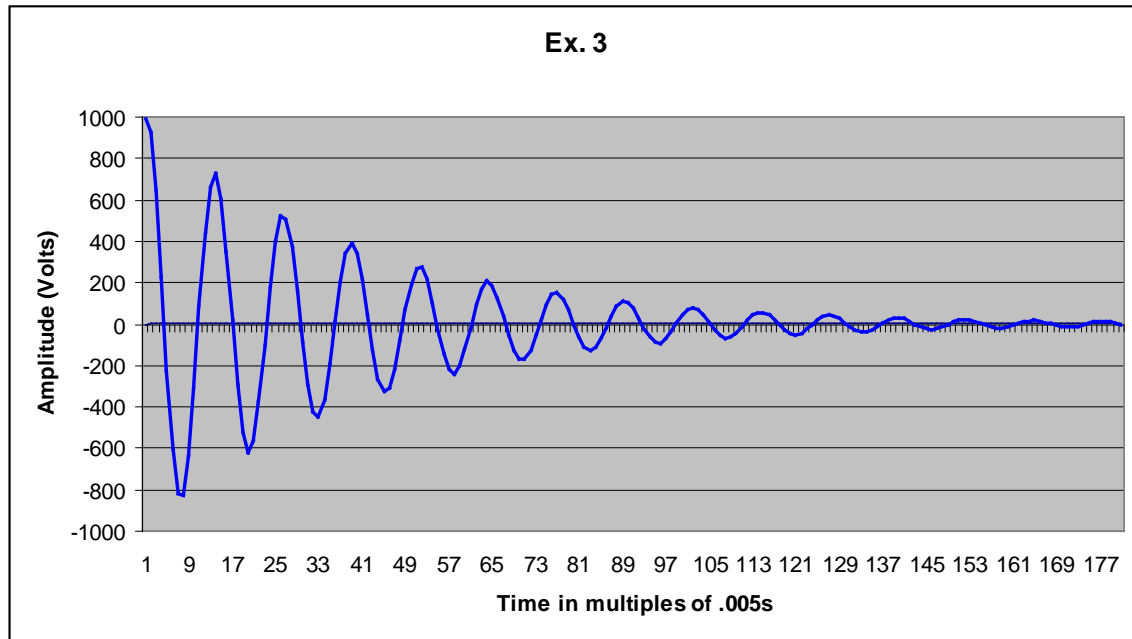

The tank exhibits a characteristic "ringing" that deteriorates over time in accordance with the system time constant. Task: identify the two components that determine the time constant; what is the theoretical result of a 0 ohm resistor? Question: is 0 ohm's possible under normal ambient conditions?

It is worth noting the magnitude of the output in response to a $\delta(t)$. The physics of an inductor is expressed as $e = L di/dt$ and at $t = 0$, di/dt approaches ∞ in the limit. We should expect a spike in voltage at $t=0$. Parallel tanks generate considerable voltage at or very near their resonant frequency and, as a designer, one must always bear in mind the consequences of voltage spikes to the remaining circuitry. Generally there are existing techniques to mitigate any deleterious results of spikes but they are not considered here,

Suppose this circuit is driven by $i_t = 10\sin(110t)$, then

$$V_{out}(s) = \frac{10000(1100)(.1s + 1)}{(s^2 + 10s + 10000)(s^2 + 110^2)} \approx \frac{(99.87)(458\angle 112^\circ)}{(s + 5)^2 + 99.87^2} + \frac{(110)(465\angle -68^\circ)}{s^2 + 110^2}$$

$$V_{out}(t) = 458e^{-5t} \sin(99.87t + 112^\circ) + 465 \sin(110t - 68^\circ) \leftarrow \text{Eq. 4}$$

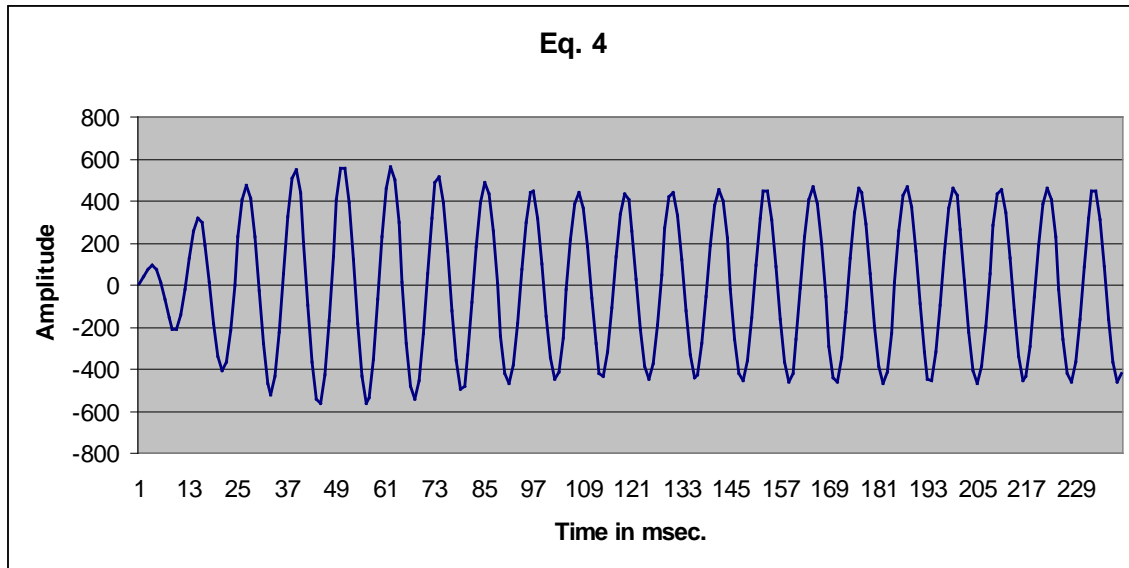

Bear in mind that $v_L = L \frac{di}{dt} = i_L(j\omega L)$, meaning that the magnitude of v_L is directly proportional to the magnitudes of both i_L & ω . The gross effect is that considerable voltage can be built across an inductor, which may present a hazard to the remaining circuitry. Of course there are techniques to control and/or limit the magnitudes, but that discussion is for a later time.

As an aside, and as a general comment: while considerable effort is maintained to monitor the correctness of all the calculations, oft times what can go wrong will go wrong. Therefore, if you discover an error, please do not hesitate to contact the company and/or the author.

Three Loop Circuit

Consider the following circuit:

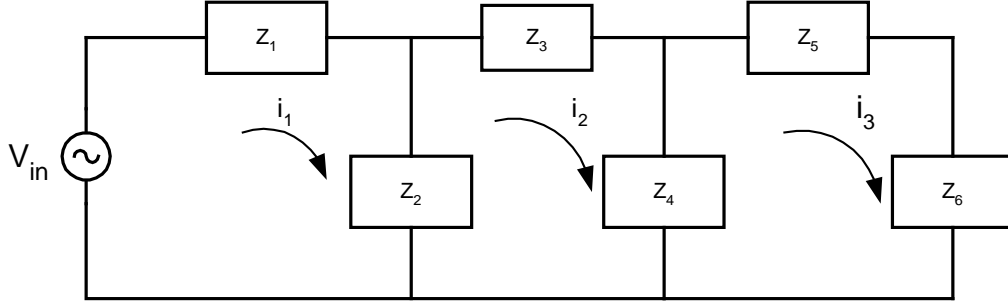

Writing the loop equations

$$\begin{aligned}
 v_{in} &= (z_1 + z_2)i_1 - z_2i_2 + 0i_3 \\
 0 &= -z_2i_1 + (z_2 + z_3 + z_4)i_2 - z_4i_3 \\
 0 &= 0i_1 - z_4i_2 + (z_4 + z_5 + z_6)i_3
 \end{aligned}$$

Writing the system equations in matrix notation

$$\begin{bmatrix}
 (z_1 + z_2) & -z_2 & 0 \\
 -z_2 & (z_2 + z_3 + z_4) & -z_4 \\
 0 & -z_4 & (z_4 + z_5 + z_6)
 \end{bmatrix}
 \begin{bmatrix}
 i_1 \\
 i_2 \\
 i_3
 \end{bmatrix}
 =
 \begin{bmatrix}
 V_{in} \\
 0 \\
 0
 \end{bmatrix}$$

Writing the determinant using the either the example or the definition contained in Appendix A

$$\begin{aligned}
 Det. &= (z_1 + z_2)(z_2 + z_3 + z_4)(z_4 + z_5 + z_6) + (-z_2)(-z_4)(0) + (0)(-z_2)(-z_4) \\
 &\quad - (0)(z_2 + z_3 + z_4)(0) - (z_1 + z_2)(z_4^2) - (z_2^2)(z_4 + z_5 + z_6)
 \end{aligned}$$

Solving for i_1 through i_3

$$i_1 = \frac{\begin{bmatrix} V_{in} & -z_2 & 0 \\ 0 & (z_2 + z_3 + z_4) & -z_4 \\ 0 & -z_4 & (z_4 + z_5 + z_6) \end{bmatrix}}{Det.} = \frac{V_{in}(z_2 + z_3 + z_4)(z_4 + z_5 + z_6) + 0 + 0 - 0 - V_{in}(z_4)^2 - 0}{Det.}$$

$$i_2 = \frac{\begin{bmatrix} (z_1 + z_2) & V_{in} & 0 \\ -z_2 & 0 & -z_4 \\ 0 & 0 & (z_4 + z_5 + z_6) \end{bmatrix}}{Det.} = \frac{0 + 0 + 0 - 0 - 0 + V_{in}z_2(z_4 + z_5 + z_6)}{Det.}$$

$$i_3 = \frac{\begin{bmatrix} (z_1 + z_2) & -z_2 & V_{in} \\ -z_2 & (z_2 + z_3 + z_4) & 0 \\ 0 & -z_4 & 0 \end{bmatrix}}{\text{Det.}} = \frac{0 + 0 + V_{in}z_2z_4 - 0 - 0 - 0}{\text{Det.}}$$

Three by three matrices get messy when there are reactive components in the circuit, and even messier at greater dimensions. But as long as the fundamentals of the matrix solution process is understood, it is recommended that you resort to the use of a computer or calculator for solutions to systems greater than or equal to 3X3. Naturally, those aides are not essential, merely convenient.

For practice, consider the following circuit:

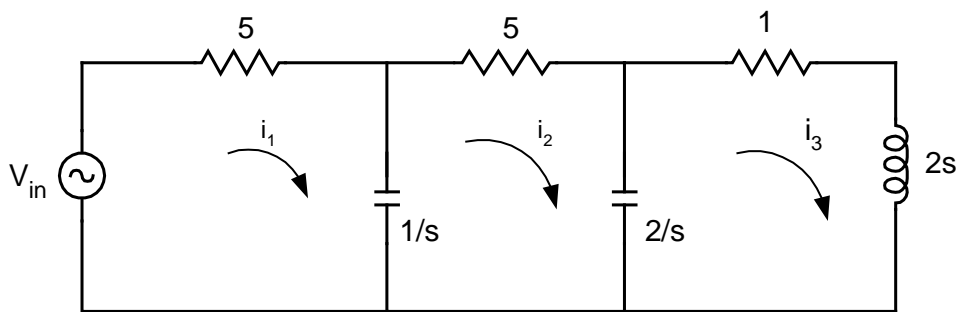

The determinant matrix is:

$$\begin{bmatrix} \left(5 + \frac{1}{s}\right) & -\frac{1}{s} & 0 \\ -\frac{1}{s} & \left(5 + \frac{3}{s}\right) & -\frac{2}{s} \\ 0 & -\frac{2}{s} & \left(1 + 2s + \frac{2}{s}\right) \end{bmatrix} =$$

$$\left(5 + \frac{1}{s}\right)\left(5 + \frac{3}{s}\right)\left(1 + 2s + \frac{2}{s}\right) + 0 + 0 - 0 - \left(5 + \frac{1}{s}\right)\left(\frac{4}{s^2}\right) - \left(\frac{1}{s^2}\right)\left(1 + 2s + \frac{2}{s}\right)$$

collecting terms (courtesy of trusty HP49 - I cannot be sure, but I would guess the internal routines use the Newton-Raphson (or variant thereof) method of finding the roots).

$$Det. = \frac{50s^3 + 65s^2 + 74s + 22}{s^2} = \frac{50(s + .391)((s + .455)^2 + .958^2)}{s^2}$$

Assume we want the impulse response across the inductor. v_{out} is then taken across the inductor, in that case

$$v_{out} = i_3(s)sL$$

$$i_3(s) = \frac{\begin{bmatrix} \left(5 + \frac{1}{s}\right) & -\frac{1}{s} & V_{in}(s) \\ -\frac{1}{s} & \left(5 + \frac{3}{s}\right) & 0 \\ 0 & -\frac{2}{s} & 0 \end{bmatrix}}{Det.}$$

$$i_3(s) = \frac{2v_{in}}{50(s + .391)((s + .455)^2 + .958^2)}$$

and

$$v_{out} = \frac{v_{in} 4s}{50(s + .391)((s + .455)^2 + .958^2)} = \frac{a}{(s + .391)} + \frac{bs + c}{(s + .455)^2 + .958^2}$$

Multiplying both sides by the common denominator

$$.08s = (a + b)s^2 + (.91a + .391b + c)s + 1.12a + .391c$$

Converting to matrix form

$$\begin{bmatrix} 1 & 1 & 0 \\ .91 & .391 & 1 \\ 1.12 & 0 & .391 \end{bmatrix} \begin{bmatrix} a \\ b \\ c \end{bmatrix} = \begin{bmatrix} 0 \\ .08 \\ 0 \end{bmatrix} \text{ Inverting the 3x3,}$$

$$\begin{bmatrix} a \\ b \\ c \end{bmatrix} = \begin{bmatrix} .549 & -1.41 & 1.5 \\ .451 & 1.41 & -1.54 \\ -.676 & 1.73 & -.802 \end{bmatrix} \begin{bmatrix} 0 \\ .08 \\ 0 \end{bmatrix} \text{ Then multiply}$$

$$\begin{bmatrix} a \\ b \\ c \end{bmatrix} = \begin{bmatrix} -.11 \\ .11 \\ .14 \end{bmatrix} \text{ So } a = -.11, b = .11 \text{ and } c = .14$$

we must account for the time constants of cosine factor, hence .14-.11, then factor .455 from .11, also ω_d must accounted for from the remaining .03 (.14-.11) to implement the sine function. Rounding is done for convenience.

$$\frac{v_{out}}{1} \approx \frac{.11(s+.455)}{(s+.455)^2+.958^2} + \frac{.03*.958}{(s+.455)^2+.958^2} - \frac{.11}{s+.391}$$

($v_{in}(s) = 1$ because $v_{in}(t) = \delta(t)$ for finding the impulse response.)

The impulse response is

$$f(t) = .11e^{-.455t} \cos(.958t) + .03e^{-.455t} \sin(.958t) - .11e^{-.391t} \quad \leftarrow \text{Eq. 5}$$

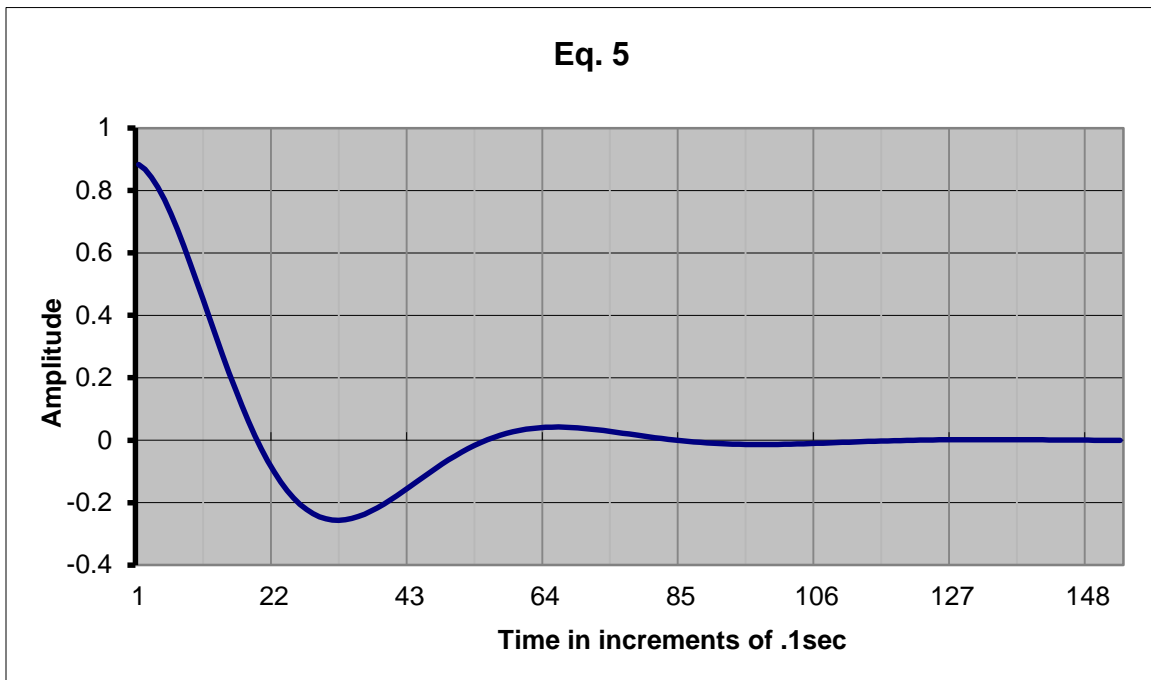

Suppose the circuit is driven at a frequency near resonance

$$V_{in} = \frac{10}{s^2 + 1}$$

then,

$$V_{out} = \frac{.8s}{(s + .391)((s + .455)^2 + .958^2)(s^2 + 1)} =$$

$$V_{out} = \frac{.8s}{(s + .391)((s + .455)^2 + .958^2)(s^2 + 1)} \approx \frac{a}{s + .391} + \frac{bs + c}{(s + .455)^2 + .958^2} + \frac{ds + e}{s^2 + 1}$$

Skipping a step or two, the matrices are

$$\begin{bmatrix} 1 & 1 & 0 & 1 & 0 \\ .91 & .39 & 1 & 1.3 & 1 \\ 2.13 & 1 & .391 & 1.48 & 1.3 \\ .91 & .391 & 1 & .44 & 1.48 \\ 1.13 & 0 & .39 & 0 & .44 \end{bmatrix} * \begin{bmatrix} a \\ b \\ c \\ d \\ e \end{bmatrix} = \begin{bmatrix} 0 \\ 0 \\ 0 \\ .8 \\ 0 \end{bmatrix}$$

inverting

$$\begin{bmatrix} a \\ b \\ c \\ d \\ e \end{bmatrix} = \begin{bmatrix} .02 & -.05 & .14 & -.37 & .94 \\ 1.47 & -.83 & -.64 & 1.25 & -.44 \\ .94 & .72 & -1.41 & .5 & .85 \\ -.49 & .89 & .49 & -.89 & -.49 \\ -.89 & -.49 & .89 & .49 & -.89 \end{bmatrix} * \begin{bmatrix} 0 \\ 0 \\ 0 \\ .8 \\ 0 \end{bmatrix}$$

multiplying

$$\begin{bmatrix} a \\ b \\ c \\ d \\ e \end{bmatrix} = \begin{bmatrix} -.29 \\ 1 \\ .4 \\ -.71 \\ .4 \end{bmatrix}$$

So

$$\frac{.8s}{(s + .391)((s + .455)^2 + .958^2)(s^2 + 1)} \approx \frac{-.29}{s + .391} + \frac{s + .4}{(s + .455)^2 + .958^2} - \frac{.71s - .4}{s^2 + 1}$$

$$\frac{.8s}{(s + .391)((s + .455)^2 + .958^2)(s^2 + 1)} \approx \frac{-.29}{s + .391} + \frac{s + .4 + .055 - .055}{(s + .455)^2 + .958^2} - \frac{.71s - .4}{s^2 + 1}$$

$$v_{out}(t) \approx e^{-.455t}(\cos(.958t) - .057\sin(.958t)) - .71\cos(t) + .4\sin(t) - .29e^{-.391t}$$

Label the above expression Eq. 6

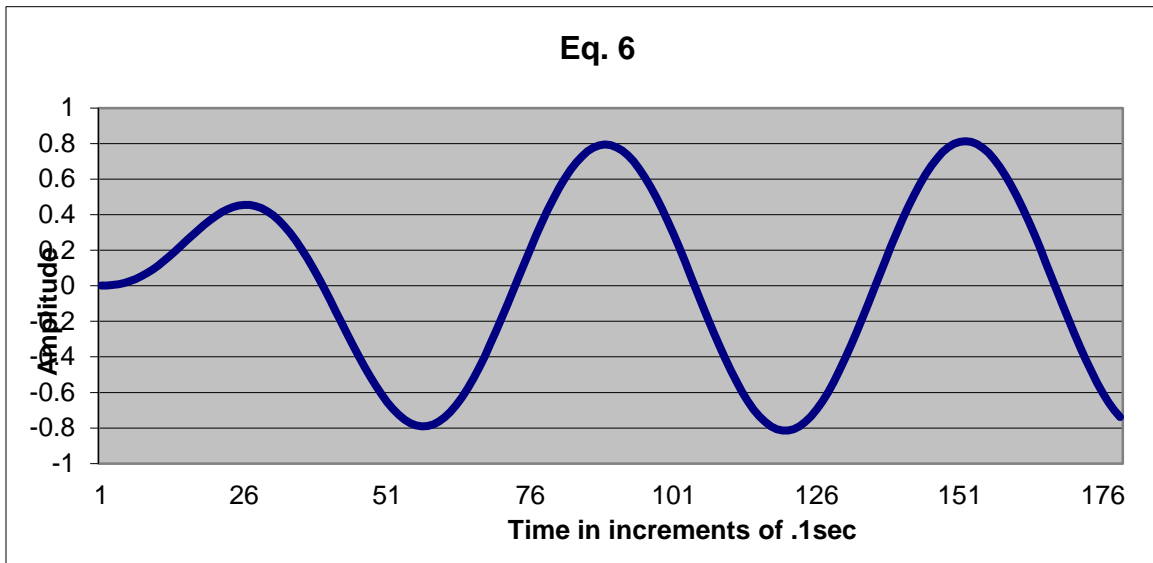

The graph of Eq. 6 illustrates the relationship between the impulse, or transient, response and the steady state response. It should be clear that while always a factor to be considered, the impulse response is short lived while the form of the steady state response mirrors the driver for this case. Filtering of non-sinus inputs will alter the form and amplitude of the output relative to the input, and we will cover some of those cases later in the series.

Transform	$f(t)$	$F(s)$
1	K	$\frac{K}{s}$
2	$Ke^{-\sigma t}$	$\frac{K}{s + \sigma}$
3	$K \sin(\omega t)$	$\frac{K\omega}{s^2 + \omega^2}$
4	$K \cos(\omega t)$	$\frac{Ks}{s^2 + \omega^2}$
5	$Ke^{-\sigma t} \sin(\omega t)$	$\frac{K\omega}{(s + \sigma)^2 + \omega^2}$
6	$Ke^{-\sigma t} \cos(\omega t)$	$\frac{K(s + \sigma)}{((s + \sigma)^2 + \omega^2)}$
7	$\delta(t)$	1
7a*	$K\delta(t)$	K
8	$Ku(t - a)$	$\frac{Ke^{-as}}{s}$
9	$f'(t)$	$sF(s) - f(0)$
10	$\int f(t)dt$	$\frac{F(s)}{s}$
11	$af(t) + bg(t)$	$aF(s) + bG(s)$
12	t	$\frac{1}{s^2}$
13	te^{-at}	$\frac{1}{(s + a)^2}$

Table 1

* K is preserved for practical circuit reasons, not for theoretical reasons as $K * \infty$ is approximately equal to ∞

It is **very important** to understand that to be able transform any $F(s)$ to an $f(t)$, $F(s)$ **must** be reduced to one of the forms so far developed. If it is not in one of these forms it cannot be operated on until it is. Study the right hand side forms, they identify the left hand side.

Appendix A Cramer's Rule Refresher

This appendix is not intended as a tutorial, but rather as a refresher for those that want a reminder of how the process proceeds.

Suppose there is a system of equations representing a simple two loop circuit containing two unknowns and two equations, such as

$$\begin{aligned}a_1 i_1 + b_1 i_2 &= V_{in} \\ a_2 i_1 + b_2 i_2 &= 0\end{aligned}$$

In the above case i_1 & i_2 are the unknowns and everything else is known.

Then using the notation of Algebra we can re-write these equations as

$$\begin{bmatrix} a_1 & b_1 \\ a_2 & b_2 \end{bmatrix} \begin{bmatrix} i_1 \\ i_2 \end{bmatrix} = \begin{bmatrix} V_{in} \\ 0 \end{bmatrix}$$

In order to solve for the two unknowns, **first** the determinant (Det.) is found by multiplying the elements of left to right diagonal, and then subtracting the multiplication of elements on the right to left diagonal.

$$\text{Det.} = a_1 b_2 - b_1 a_2$$

Next, to find i_1 , the rightmost column containing V_{in} & 0 is substituted for the column containing a_1 & a_2 .

$$\begin{bmatrix} V_{in} & b_1 \\ 0 & b_2 \end{bmatrix}$$

Then find the determinant of that new matrix.

$$V_{in} b_1 - b_2 0$$

Next divide by the Det., the result is the value of i_1 . So

$$i_1 = \frac{V_{in}b_1 - b_2 \cdot 0}{a_1b_2 - b_1a_2}$$

The term $b_2 \cdot 0$ is zero, and is included only for completeness as the driver in the second loop is not always zero.

Finally solve for i_2 by substituting V_{in} & 0 for the column containing b_1 & b_2 .

$$\begin{bmatrix} a_1 & V_{in} \\ a_2 & 0 \end{bmatrix}$$

and divide by Det.

$$i_2 = \frac{a_1 \cdot 0 - V_{in}a_2}{a_1b_2 - b_1a_2}$$

Please bear in mind that the second loop may have a driver and therefore the left hand side of the describing equation will not be zero. Also, there is no constraint on the matrix elements to be real, in fact in actual circuitry they are more than often complex. Also because the rules of Laplace Transform pairs allows addition, the whole set of equations may be written in the 's' domain.

Optional: For a short discussion of why this technique works, see appendix B.

An example;

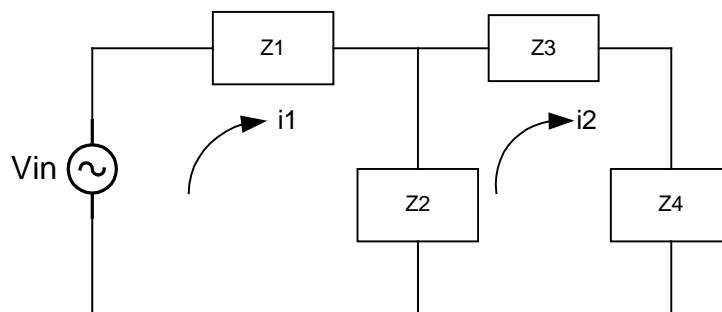

From the above,

$$V_{in} = i_1(z_1 + z_2) - i_2 z_2$$

$$0 = -i_1 z_2 + i_2(z_2 + z_3 + z_4)$$

The determinant is $(z_1 + z_2)(z_2 + z_3 + z_4) - z_2^2$ or

$$\text{Det.} = z_1 z_2 + z_1 z_3 + z_1 z_4 + z_2 z_3 + z_2 z_4$$

$$\text{Then } i_1 = \frac{V_{in}(z_2 + z_3 + z_4) + z_2 \cdot 0}{\text{Det.}}$$

$$\text{and } i_2 = \frac{i_1 \cdot 0 + V_{in}(z_2)}{\text{Det.}}$$

Assume: $V_{in} = 10$, $z_1 = z_4 = 10$, $z_2 = z_3 = 5$

$$\text{Then Det. is } \begin{bmatrix} 15 & -5 \\ -5 & 20 \end{bmatrix} = 275$$

and

$$i_1 = \frac{\begin{bmatrix} 10 & -5 \\ 0 & 20 \end{bmatrix}}{275} = \frac{200}{275} \cong .73$$

and

$$i_2 = \frac{\begin{bmatrix} 15 & 10 \\ -5 & 0 \end{bmatrix}}{275} = \frac{50}{275} \cong .18$$

Suppose $V_{out} = i_2 z_4$, then $V_{out} = 1.8V$

For a three loop circuit, there will be three equations and three unknowns.

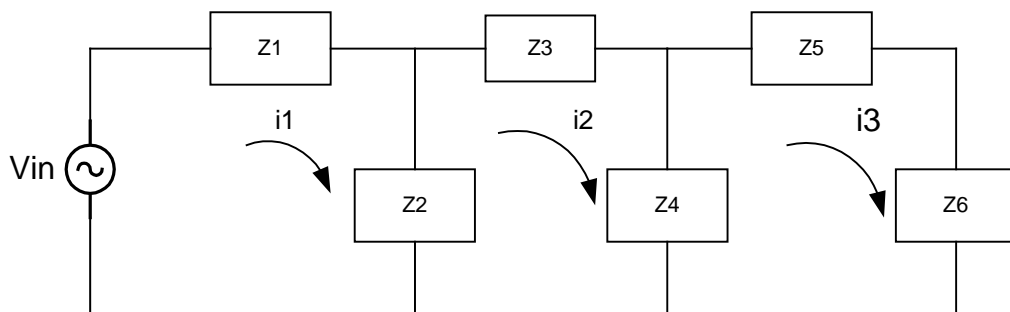

The procedure for any matrix greater than a 2x2 as in the above example, is extended and modified slightly. In the case of the three loop circuit there are three columns and three rows;

$$\begin{aligned} V_{in} &= i_1(z_1 + z_2) - i_2(z_2) + i_3(0) \\ 0 &= -i_1z_2 + i_2(z_2 + z_3 + z_4) - i_3z_4 \\ 0 &= i_1(0) - i_2z_4 + i_3(z_4 + z_5 + z_6) \end{aligned}$$

The determinant matrix will be

$$\begin{bmatrix} (z_1 + z_2) & -z_2 & 0 \\ -z_2 & (z_2 + z_3 + z_4) & -z_4 \\ 0 & -z_4 & (z_4 + z_5 + z_6) \end{bmatrix}$$

At this point a modification occurs. There are three columns, and therefore there must be three terms for both the left and right hand diagonals. A frequent crutch that works is to merely copy columns 1 & 2 to the right of the matrix; that yields three complete diagonals in each direction. To extend the rule, an nxn matrix requires n diagonals in each direction.

$$\begin{bmatrix} (z_1 + z_2) & -z_2 & 0 \\ -z_2 & (z_2 + z_3 + z_4) & -z_4 \\ 0 & -z_4 & (z_4 + z_5 + z_6) \end{bmatrix} \begin{bmatrix} (z_1 + z_2) & -z_2 \\ -z_2 & (z_2 + z_3 + z_4) \\ 0 & -z_4 \end{bmatrix}$$

the determinant then is

$$\begin{aligned} &(z_1 + z_2)(z_2 + z_3 + z_4)(z_4 + z_5 + z_6) + (-z_2)(-z_4)(0) + (0)(-z_2)(-z_4) \\ &- (0)(z_2 + z_3 + z_4)(0) - (z_1 + z_2)(z_4^2) - (z_2^2)(z_4 + z_5 + z_6) \end{aligned}$$

As an example, suppose that three equations in three unknown are

$$\begin{aligned} 20 &= 15i_1 - 5i_2 \\ 0 &= -5i_1 + 20i_2 - 5i_3 \\ -5 &= -5i_2 + 15i_3 \end{aligned}$$

The matrices are:

$$\begin{bmatrix} 15 & -5 & 0 \\ -5 & 20 & -5 \\ 0 & -5 & 15 \end{bmatrix} \begin{bmatrix} i_1 \\ i_2 \\ i_3 \end{bmatrix} = \begin{bmatrix} 20 \\ 0 \\ -5 \end{bmatrix}$$

The determinant is

$$\begin{bmatrix} 15 & -5 & 0 \\ -5 & 20 & -5 \\ 0 & -5 & 15 \end{bmatrix} \begin{bmatrix} 15 & -5 \\ -5 & 20 \\ 0 & -5 \end{bmatrix}$$

$$(15)(20)(15) + (-5)(-5)(0) + (0)(-5)(-5) - (0)(20)(0) - (15)(-5)(-5) - (-5)(-5)(15) = 3750$$

$$i_1 = \frac{\begin{bmatrix} 20 & -5 & 0 \\ 0 & 20 & -5 \\ -5 & -5 & 15 \end{bmatrix}}{3750} = 1.433$$

$$i_2 = \frac{\begin{bmatrix} 15 & 20 & 0 \\ -5 & 0 & -5 \\ 0 & -5 & 15 \end{bmatrix}}{3750} = .3$$

$$i_3 = \frac{\begin{bmatrix} 15 & -5 & 20 \\ -5 & 20 & 0 \\ 0 & -5 & -5 \end{bmatrix}}{3750} = -.233$$

The minus sign on i_3 merely means that it is flowing in a direction opposite to the other two.

For matrices greater than three rows by three columns (3x3), the labor goes up significantly, and the use of a calculator such as an HP49 or a computer program similar to MATLAB or wxMaxima is very helpful. However for those that enjoy the labor the following rules are offered:

There are other, equally valid techniques from our slide-rule days, such as Gaussian Elimination, Matrix Inversion and the use of Minors, but all in all once you understand the foundations of the process the use of a good

calculator is incredibly labor and error saving. Of course it is the understanding of these techniques that form the foundations for the programming in the calculator's ROM library.

The determinant is the algebraic sum of all the possible products where:

- a. each product has factors of one element, and only one, from each row and column
- b. a plus sign is assigned to each product if the number of column inversions is even, 0 inversions being defined as even. A minus sign is assigned to a product that has an odd number of column inversion.

An inversion, by illustration, is that if the natural order of counting is 1234 and a product is formed from columns 1423 then it contains two inversions; to change 1423 to 1234, the 4 must move two places to the right. 4321 has six inversions as the 4 moves three places, the 3 moves two places and the 2 moves one to create 1234.

These rules are simply the procedure used for a 3x3 extended to an nxn.

Appendix B Foundations

Suppose

$$Ax + By = P$$

$$Cx + Dy = Q$$

then $By = P - Ax$ and $y = \frac{P - Ax}{B}$

then $Cx + D\left(\frac{P - Ax}{B}\right) = Q$ and becomes $CBx + DP - ADx = BQ$

which, in turn becomes $x(CB - AD) = BQ - DP$

or $x = \frac{PD - BQ}{AD - BC}$

Using Cramer's rule the matrices for the two initial equations are

$$x = \frac{\begin{bmatrix} P & B \\ Q & D \end{bmatrix}}{\begin{bmatrix} A & B \\ C & D \end{bmatrix}} = \frac{PD - BQ}{AD - BC}$$

For those with infinite stamina this procedure can be extended to any number of equations that possess the same number in unknowns. But the author, being a member of Lazyhood Incorporated, uses mechanical means once the theory is established.

Appendix C Common Base Amplifier

Consider the following circuit

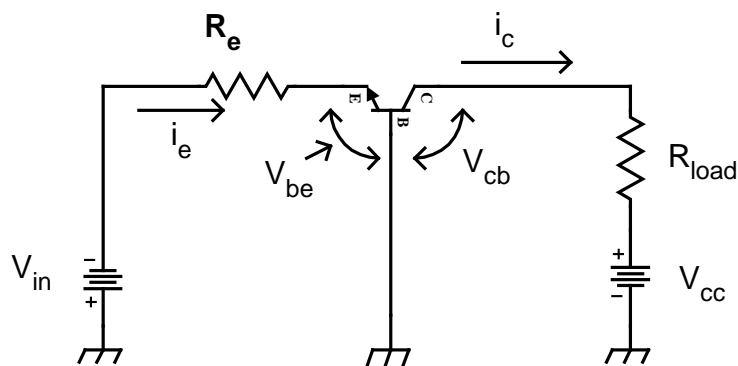

This circuit consists of an NPN transistor, forward biased emitter to base (V_{be}) and reverse biased collector to base (V_{cb}). Typically V_{be} is on the order of approximately .7 volts, so the current through R_e , is

$$I_e \approx \frac{V_{in} - .7}{R_e}$$

The physics of the transistor are such that the current through the collector and hence through R_{load} is always .98-.99 I_e (true within the manufacturers operating characteristics range for the particular transistor type). Therefore adjusting V_{in} adjusts I_e , which in turn controls the load current. In short

$$I_c \approx .99I_e$$

Obviously this makes the current through the load utterly dependent on I_e , which in turn is dependent upon the values chosen for R_e & V_{in} .

The above is a very primitive version of a common base amplifier, and design considerations of coupling, impedance, bandwidth, emitter resistance, etc., have been utterly ignored so as to focus on the current generator effect at the collector.

The most common point of confusion is that if the collector current is 99% of the emitter current, what has happened to ohm's law in the collector to base loop. Nothing actually. Kirchhoff's voltage equation for that loop is

$$V_{cc} \approx I_e R_{load} + V_{cb}$$

As the transistor is active, and is constrained by it's physics, V_{cb} adjusts to accommodate the voltage law.